

# **GNSS Dual-band High Precision RTK Module**

## **TAU951M-P2 Series**

Datasheet V1.0

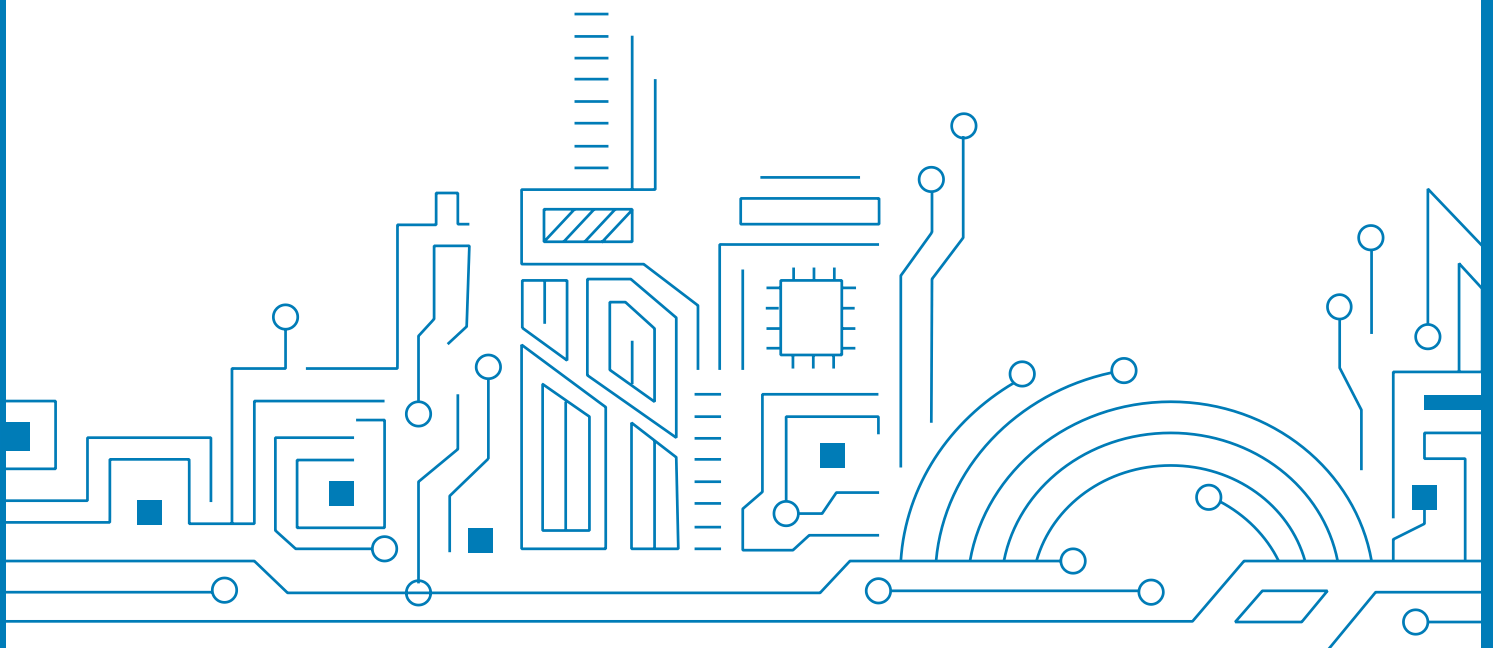

## Notice, Statement and Copyright

ALLYSTAR Technology offers this document as a service to its customers, to support application and engineering efforts that use the products designed by ALLYSTAR Technology. Products and specifications discussed herein are for reference purposes only. Performance characteristics listed in this document do not constitute a warranty or guarantee of product performance.

ALLYSTAR Technology assumes no liability or responsibility for any claims or damages arising out of the use of this document, or from the use of integrated circuits based on this document, including, but not limited to claims or damages based on infringement of patents, copyrights or other intellectual property rights.

This document contains proprietary technical information which is the property of ALLYSTAR Technology, copying of this document and giving it to others and using or communication of the contents thereof, are forbidden without express authority. Offenders are liable to the payment of damages. ALLYSTAR Technology reserves the right to make changes in its products, specifications and other information at any time without notice.

For more recent documents, please visit [www.allystar.com](http://www.allystar.com).

Copyright © ALLYSTAR Technology (Shenzhen) Co., Ltd. 2024. All rights reserved.

## About the Document

### ■ Basic info

<b>Document applies to</b>	TAU951M-P2 Series
<b>Document type</b>	Datasheet
<b>Revision and date</b>	V1.0/2024-01

## CONTENTS

<b>1</b>	<b>SYSTEM OVERVIEW .....</b>	<b>6</b>
1.1	Overview .....	6
1.2	Product Photo .....	6
1.3	Features .....	6
1.4	Block diagram .....	8
1.5	Specifications .....	8
<b>2</b>	<b>PIN DESCRIPTION .....</b>	<b>10</b>
2.1	Pin Assignment .....	10
2.2	Detailed pin descriptions .....	11
<b>3</b>	<b>ELECTRICAL CHARACTERISTICS .....</b>	<b>12</b>
3.1	Absolute Maximum Rating .....	12
3.2	DC Characteristics .....	12
3.3	ESD .....	12
<b>4</b>	<b>HARDWARE DESCRIPTION .....</b>	<b>13</b>
4.1	Connecting Power .....	13
4.2	Power on/off Sequence .....	13
4.3	Antenna Design .....	14
4.3.1	ANT_BIAS .....	14
4.4	Reset and Mode Control .....	14
<b>5</b>	<b>MECHANICAL SPECIFICATION .....</b>	<b>16</b>
<b>6</b>	<b>REFERENCE DESIGN .....</b>	<b>17</b>
6.1	Reference Design .....	17
6.2	PCB Footprint Reference .....	19
6.3	Layout Notes .....	20
<b>7</b>	<b>DEFAULT MESSAGE .....</b>	<b>21</b>
<b>8</b>	<b>PACKAGING INFORMATION .....</b>	<b>22</b>
8.1	Packing .....	22
8.1.1	Tape and Reel .....	22
8.1.2	Shipment Packaging .....	23
8.2	Storage .....	23
8.3	ESD Handling .....	24
8.3.1	ESD Handling Precautions .....	24
8.3.2	ESD Protection Measures .....	24
8.3.3	Moisture Sensitivity Level .....	24

<b>9</b>	<b>LABELING AND ORDERING INFORMATION .....</b>	<b>25</b>
9.1	Labeling .....	25
9.2	Ordering info .....	25
<b>10</b>	<b>REVISION HISTORY .....</b>	<b>26</b>

## List of Figures

Figure 1	TAU951M-P2 Series .....	6
Figure 2	Block diagram .....	8
Figure 3	Pin assignment (top view) .....	10
Figure 4	System power on sequence .....	13
Figure 5	Switching the operation mode .....	15
Figure 6	Reset Timing .....	15
Figure 7	Dimensions .....	16
Figure 8	Reference design of active ant. supplied by ANT_BIAS .....	18
Figure 9	Reference design of active ant. supplied by external power .....	18
Figure 10	Reference design of passive ant. ....	19
Figure 11	PCB Footprint Reference .....	19
Figure 12	Tape dimensions .....	22
Figure 13	Reel dimensions .....	23
Figure 14	Packaging .....	23

## List of Tables

Table 1	TAU951M-P2 Series .....	7
Table 2	GNSS reception .....	7
Table 3	Specifications .....	8
Table 4	Detailed pin descriptions .....	11
Table 5	Absolute rating .....	12
Table 6	DC Characteristics .....	12
Table 7	ESD protection performance .....	12
Table 8	Dimensions .....	16
Table 9	Default message .....	21
Table 10	Packing hierarchy .....	22
Table 11	Ordering codes .....	25

## 1 SYSTEM OVERVIEW

### 1.1 Overview

The TAU951M-P2 series is a set of GNSS dual-band high-precision RTK navigation and positioning module which is based on the state of art CYNOSURE IV dual-core SoC chip. It is capable of tracking all global civil navigation systems (BDS, GPS, GLONASS, Galileo, QZSS, NavIC, and SBAS), as well as BDS-3 signals.

The latest dual-core architecture CYNOSURE IV adopts 22 nm process, with built-in dual-core MCU and 8Mbit MRAM, integrating multi-band multi-system GNSS RF and baseband. This newly designed architecture makes the module achieve centimeter level position accuracy and higher sensitivity, greater for improved jam resistance and multipath, and provide a highly robust service in complicated environment.

Along with its preeminent performance, the compact size (16.0×12.2×2.4 mm) of TAU951M-P2 series of LCC package with lower consumption makes it suitable for various demands under different conditions. It can be widely used in mower, smart driving, surveying and mapping, unmanned aerial vehicles (UAVs), intelligent agriculture, and other fields.

### 1.2 Product Photo

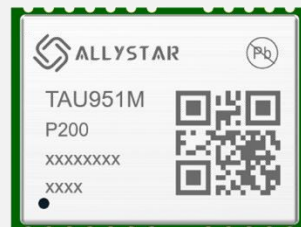

Figure 1 TAU951M-P2 Series

### 1.3 Features

- Concurrent reception of multi-band multi-system satellite signals
- Tracking 128 GNSS signal channels at the same time
- Support BDS-3 signals: B1C, B2a
- Support PPP-B2b/PPP/PPP-RTK (upon request)
- Internal PVT, RTD, and RTK Engine
- Update rate up to 10 Hz

- Support A-GNSS
- Smart jammer detection and suppression
- Support four kinds of low power mode

**Table 1 TAU951M-P2 Series**

Product	GNSS						Feature						Inf.	Accuracy		Grade					
	Bands (S/D/T)	BDS	GPS/QZSS	GLONASS	Galileo	NavIC	SBAS	Built-in SAW	Built-in LNA	RTD	RTK	Oscillator	SPI	PPS	UART	I2C	Meter	Sub-meter	Centimeter	Industrial	Automotive
TAU951M-P200	D	●	●	●	●	○	●	●	●	●	●	T	○	●	●	○			●	●	

T = TCXO

○ = Supported upon request with special firmware

**Table 2 GNSS reception**

Mode	GPS/QZSS					BDS						GLONASS		Galileo			NavIC	SBAS	
	L1CA	L1C	L2C	L5	L6	B1I	B1C	B2I	B2b	B2a	B3I	G1	G2	E1	E5a	E5b	E6	L5	L1
A (default)	●	*[1]	--	●	--	●	●	--	--	●	--	●	--	●	●	--	--	*[1]	●
B	●	*[1]	●	--	--	●	●	●	--	--	--	●	●	●	--	●	--	--	●
C	●	●	●	--	--	●	●	--	--	--	--	●	--	●	--	--	--	--	●

\* [1] Supported upon request with special firmware

## 1.4 Block diagram

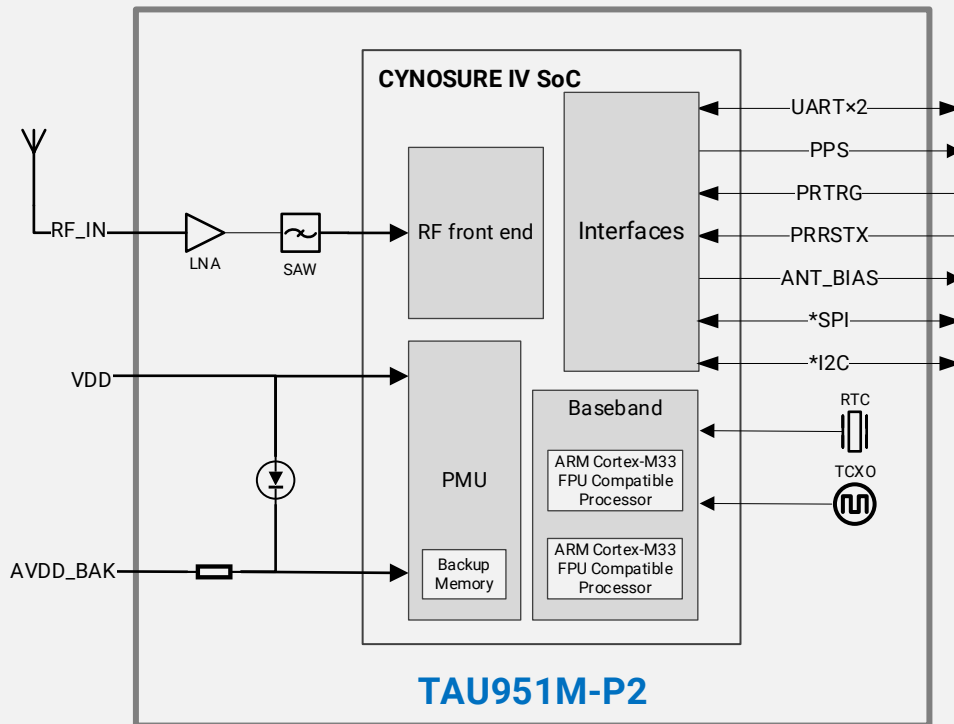

Figure 2 Block diagram

## 1.5 Specifications

Table 3 Specifications

Parameter	Specification	
GNSS reception	BDS, GPS, QZSS, GLONASS, Galileo, NavIC, SBAS	
Channel	128	
Update rate	10 Hz Max.	
Position accuracy	GNSS	1.0m CEP
	SBAS	< 1.0m CEP
	RTK	1.0 cm + 1 ppm (H) 2.0 cm + 1 ppm (V)
Velocity & Time accuracy	GNSS	0.05 m/s CEP
	1PPS	20 ns RMS
TTF	Hot start	1s
	Cold start	27s
RTK	Convergence time	< 10s
	Reliability	> 99.9%
Sensitivity <sup>[1]</sup>	Cold start	-148 dBm



Parameter	Specification		
	Hot start	-155 dBm	
	Reacquisition	-158 dBm	
	Tracking & navigation	-165 dBm	
Protocol	NMEA-0183		
	RTCM 2.X, RTCM 3.X		
Baudrate	115200 bps, by default		
Operating condition	Main supply	1.75V to 3.63V	
	Digital I/O supply	1.75V to 3.63V	
	Backup supply	1.62V to 3.63V	
Power consumption	Tracking	GNSS	30 mA @ 3.3V
		Single system	18 mA @ 3.3V
	Standby	Data backup	16 uA
		RTC	1.4 uA
Serial interface	UART		2
	SPI <sup>[2]</sup>		1
	I2C <sup>[2]</sup>		1
Operating limit	Velocity	515 m/s	
	Altitude	18,000m	
Environmental conditions	Operating temperature	-40°C to +85°C	
	Storage temperature	-40°C to +90°C	
	Humidity	95% RH	
Size	16.0×12.2×2.4 mm 24PIN LCC		

\* [1] Demonstrated with a good external LNA

\* [2] Supported upon request with special firmware.

## 2 PIN DESCRIPTION

### 2.1 Pin Assignment

13	GND	GND	12
14	ANT_ON	RF_IN	11
15	SPI_CLK	GND	10
16	SPI_DO/UOUT1	ANT_BIAS	9
17	SPI_DI/UIIN1	PRRSTX	8
<b>TAU951M-P2</b>			
<b>Series</b>			
18	I2C_SDA	Reserved	7
19	I2C_SCL	Reserved	6
20	UOUT0	RTK_INT	5
21	UIN0	Reserved	4
22	AVDD_BAK	PPS	3
23	VDD	PRTRG	2
24	GND	SPI_CS	1

Figure 3 Pin assignment (top view)

## 2.2 Detailed pin descriptions

**Table 4 Detailed pin descriptions**

Function	Symbol	No.	I/O	Description
Power	GND	10, 12, 13, 24	G	Ground
	VDD	23	P	Main supply input.
	AVDD_BAK	22	P	Backup supply input.
Antenna	ANT_BIAS	9	O	RF section output voltage. Used to power the external active antenna. Leave it floating if not used.
	RF_IN	11	I	RF signal input.
	ANT_ON	14	O	External active antenna ON/OFF. Leave it floating if not used.
SPI <sup>[1]</sup>	SPI_CS	1	I/O	SPI interface. Leave it floating if not used.
	SPI_CLK	15	I	SPI clock. Leave it floating if not used.
	SPI_DO/UOUT1	16	O	SPI data output, or UART1 serial data output. Default as UART1. Leave it floating if not used.
	SPI_DI/UIIN1	17	I	SPI data input, or UART1 serial data input. Default as UART1. Leave it floating if not used.
I2C <sup>[1]</sup>	I2C_SDA	18	I/O	I2C data. Leave it floating if not used.
	I2C_SCL	19	I/O	I2C clock. Leave it floating if not used.
UART	UOUT0	20	O	UART0 serial data output.
	UIN0	21	I	UART0 serial data input.
Others	RTK_INT	5	O	RTK status output. Leave it floating if not used.
	PRRSTX	8	I	External reset, low active. Connect PRRSTX to the MCU during design. To meet the power on/off sequence control, do not leave this pin floating.
	PRTRG	2	I	Mode selection, or the trigger input to wake up the system.
	PPS	3	O	Time pulse output (PPS). Leave it floating if not used.
	Reserved	4, 6, 7	--	Reserved pin. Leave it floating.

\* [1] Supported upon request with special firmware

## 3 ELECTRICAL CHARACTERISTICS

### 3.1 Absolute Maximum Rating

Table 5 Absolute rating

Symbol	Parameter	Min.	Max.	Unit
VDD	Power input for the main power domain	-0.5	3.63	V
AVDD_BAK	Power input for the backup power domain	-0.5	3.63	V
V <sub>I</sub> max	Voltage input of I/O pin	-0.5	3.63	V
T <sub>env</sub>	Operation temperature	-40	85	°C
T <sub>storage</sub>	Storage temperature	-40	90	°C
T <sub>solder</sub>	Solder reflow temperature	--	260	°C

### 3.2 DC Characteristics

Table 6 DC Characteristics

Symbol	Parameter	Min.	Typ.	Max.	Unit
VDD	Power input for the main power domain	1.75	3.3	3.63	V
AVDD_BAK	Power input for the backup power domain	1.62	3.3	3.63	V
I <sub>ANT_BIAS</sub>	ANT_BIAS output current	--	--	25	mA
V <sub>ANT_BIAS</sub>	ANT_BIAS output voltage	--	VDD-0.2	--	V

### 3.3 ESD

Please add appropriate ESD protection on the module during design to ensure its functionality according to its application field.

Table 7 ESD protection performance

Pin	Contact discharge	Air discharge	Condition
RF_IN	±2kV	±4kV	HBM, 45% RH, 25°C
GND	±2kV	±4kV	
Others	±2kV	±4kV	

## 4 HARDWARE DESCRIPTION

### 4.1 Connecting Power

The module has two power supply pins: VDD and AVDD\_BAK. The main power is supplied through the VDD pin, and the backup power is supplied through the AVDD\_BAK pin. In order to ensure the positioning performance, please control the ripple of the module power supply as possible. It is recommended to use the LDO of a current above 200 mA, and PSRR not less than 70 dB for power supply. Add a magnetic bead on VDD pin if the power noise is high.

If the power for VDD pin is off, the real-time clock (RTC) and battery backed RAM (BBR) are supplied through the AVDD\_BAK pin. Thus, orbit information and time can be maintained and will allow a Hot or Warm start. If no backup battery is connected, the module will perform a cold start at every power-up if no aiding data are sent to the module.

**Note:** If no backup supply is available, connect AVDD\_BAK pin to VDD.

### 4.2 Power on/off Sequence

A permanent damage may occur with inappropriate power on sequence. So, please follow the rules below during design. To meet the requirement of controlling the power on/off sequence of the module, please connect the external reset pin (PRRSTX) to the MCU. Or, use a reset IC to control the sequence. It is recommended to adopt a low active, open-drain IC with 2.63V reset voltage threshold (APX803-26, SGM803B-RX, and UM803RS are preferred).

When both backup and main supply power on from their off state, external reset (PRRSTX) must be active and hold more than 5 ms after both backup supply and main supply reach the minimum operating voltage. The system power on sequence is illustrated in Figure 4 System power on sequence.

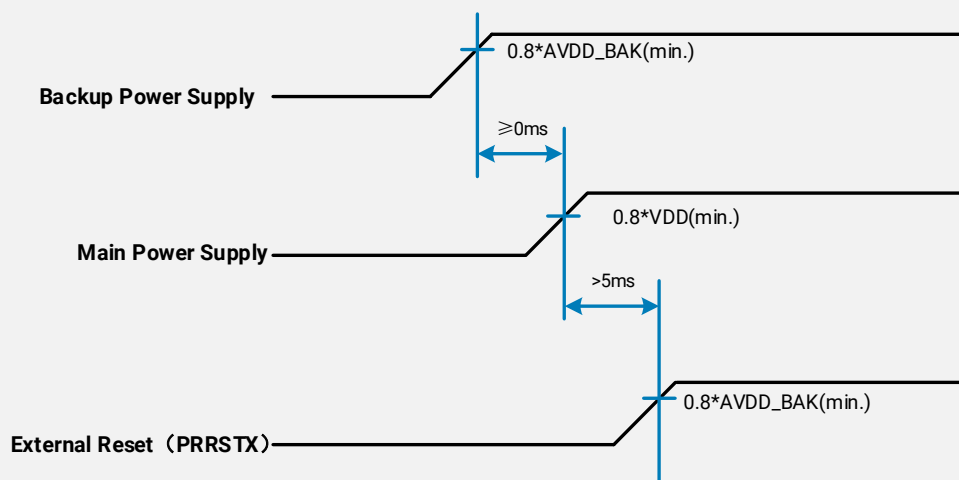

Figure 4 System power on sequence

## 4.3 Antenna Design

There is a built-in LNA and SAW in the module. It is recommended to use an active antenna with gain less than 30 dB and the noise figure less than 1.5 dB.

### 4.3.1 ANT\_BIAS

The module has built-in short circuit detection and open circuit detection function, which can detect the status of normal connection, and send out antenna status prompt message in NMEA data.

- **Short circuit protection**
  - » The module provides short circuit detection and protection functions for the antenna. Once an overcurrent is detected at the ANT\_BIAS port, the module will restrict current output automatically to protect it from damages.
- **Open circuit detection**
  - » The module can detect an open circuit in the antenna. Users can judge it from antenna status messages.

If an external power supply is used to power the antenna or a passive antenna is used, the antenna detection function will not work.

## 4.4 Reset and Mode Control

The operation mode of GNSS module is controlled by PRRSTX and PRTRG pin. While the module works in normal operation, keep PRRSTX and PRTRG pins at high level. The module will enter reset state when PRRSTX being low level (see Figure 6 Reset Timing). Operate PRTRG and PRRSTX pins as the following instructions to enter **BootROM Command Mode** to update firmware. Please be aware that UART1 cannot be used for firmware upgrade.

- Keep PRTRG pin floating during system power-up or the external reset (PRRSTX from low to high), and the module will enter **User Normal Mode**.
- Drive PRTRG pin to low or connect PRTRG to GND directly (not by pull-down resistance) during system power-up or the external reset (PRRSTX from low to high), and the system enters **BootROM Command Mode** at PRTRG pin being released from low to floating state, and ready for firmware upgrading command.

When connecting PRRSTX and PRTRG to any MCU IO, DO NOT use the pull-up or pull-down resistance.

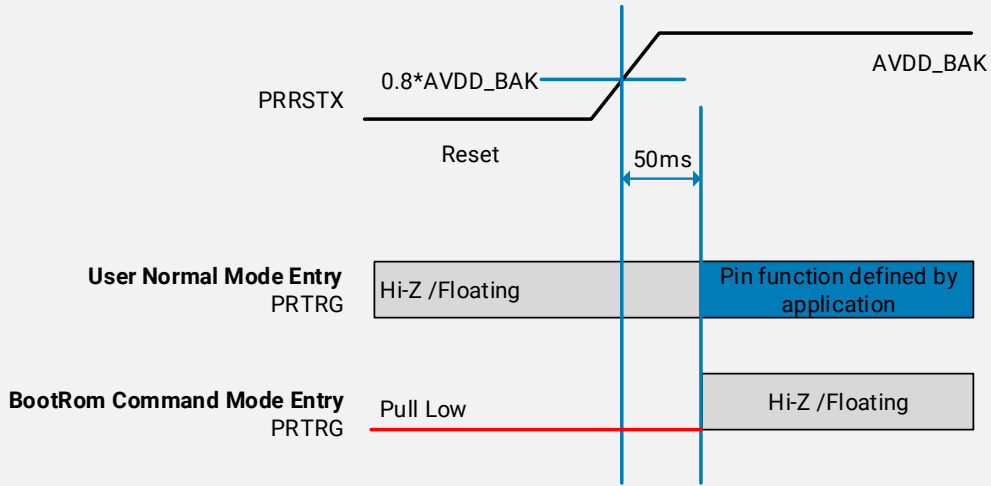

Figure 5 Switching the operation mode

Parameter	Symbol	Pin	Condition	Min.	Typ.	Max.	Unit
Reset Timing	$t_{RSTL}$	PRRSTX	Connected to a stable power source, and TCXO clock remains stable.	100	--	--	mS

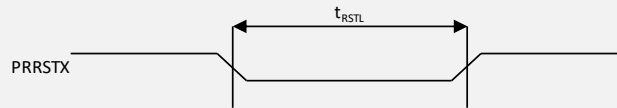

Figure 6 Reset Timing

## 5 MECHANICAL SPECIFICATION

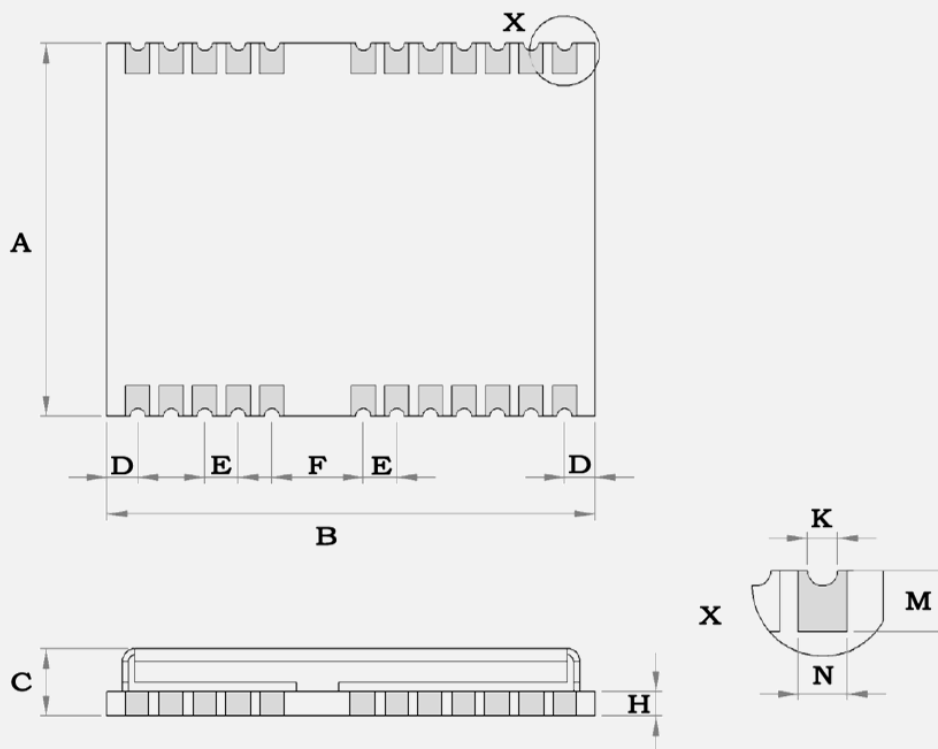

Figure 7 Dimensions

Table 8 Dimensions

Symbol	Min.(mm)	Typ.(mm)	Max.(mm)
A	12.0	12.2	12.4
B	15.8	16.0	16.2
C	2.2	2.4	2.6
D	0.9	1.0	1.3
E	1.0	1.1	1.2
F	2.9	3.0	3.1
H	-	0.8	--
K	0.4	0.5	0.6
M	0.8	0.9	1.0
N	0.7	0.8	0.9



## 6 REFERENCE DESIGN

### 6.1 Reference Design

This section provides a full elaboration for the reference design of TAU951M-P2 series modules. For more detailed information, please refer to *Hardware Application Guide for GNSS Modules*.

Please follow these instructions during hardware design:

- 1) A 27-39 nH inductor is used only when an active antenna is connected, and no need for a passive antenna. The active antenna is preferred to ensure the positioning performance.
- 2) The antenna detection is achieved through detecting the ANT\_BIAS current, whose maximum output value is 35 mA. An external power supply is required to power the antenna if the power consumption of the active antenna is greater than 35 mA. When using an external power supply or a passive antenna, the module cannot detect the antenna status, and the user needs to add a detection circuitry externally to perform antenna detection.
- 3) In the case of using an external power supply to power the antenna, it is recommended to use a 100 pF stopping capacitor to avoid the RF interface damage because of the inconsistent voltage.
- 4) A diode is used to connect the AVDD\_BAK pin and VDD pin internally, which can charge the external backup battery. See 1.4 Block diagram for details.
- 5) Due to the strong drive capability of the UART pin, installing an RC circuit, instead of a pull-up resistance, can effectively prevent the UART signal from interfering with other signals.
- 6) Connect the PRRSTX pin to the MCU to control the power on/off sequence. Or, the module is likely to be damaged.
- 7) Connect the PRTRG pin to the MCU for upgrading. Or, the OTA upgrade will not function.
- 8) When connecting the PRRSTX and PRTRG to any MCU IO, adopt the IO pin with OD output function, and do not include any pull-up or pull-down resistance to the PRRSTX and PRTRG pin.

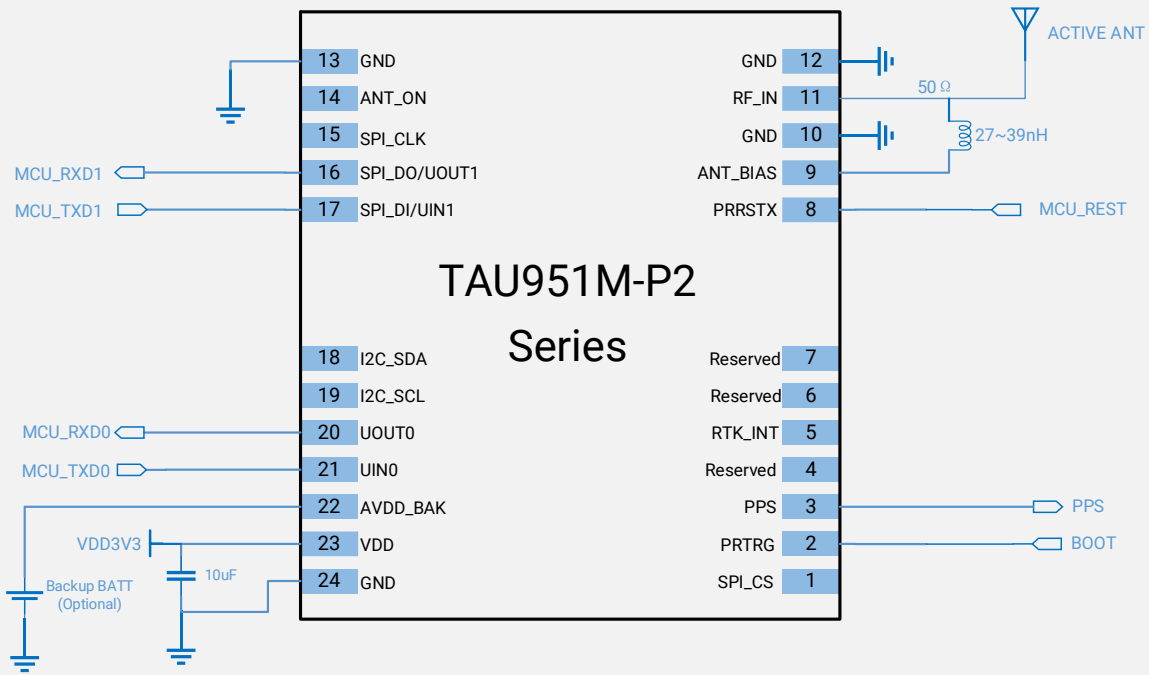

Figure 8 Reference design of active ant. supplied by ANT\_BIAS

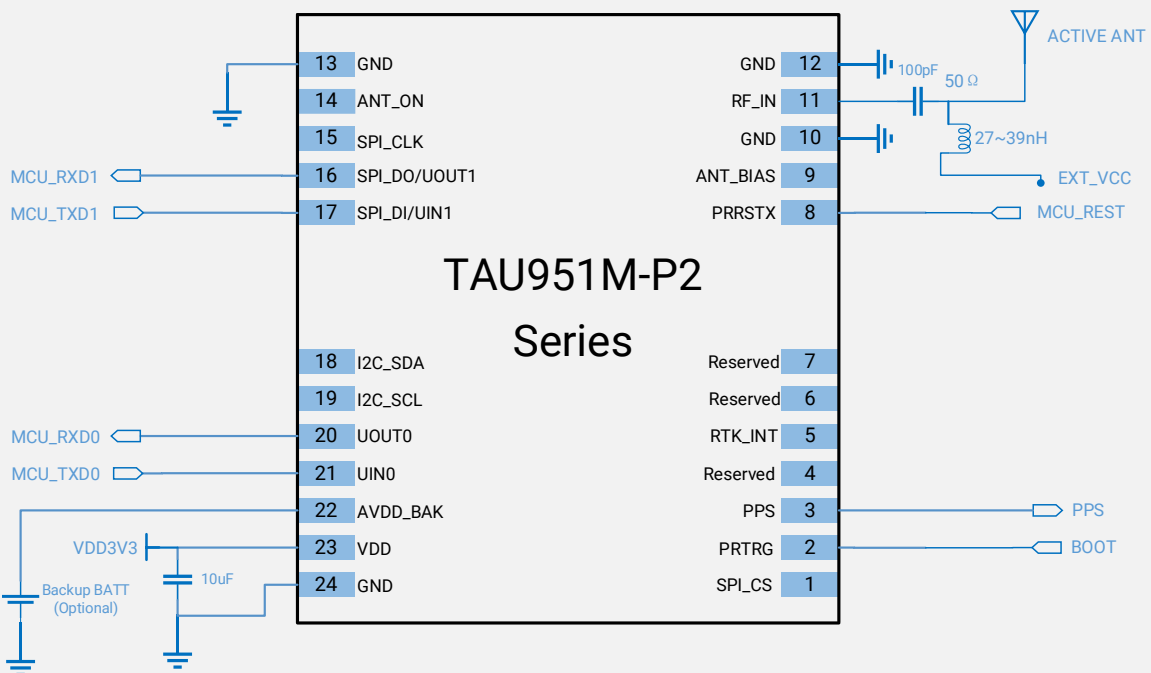

Figure 9 Reference design of active ant. supplied by external power

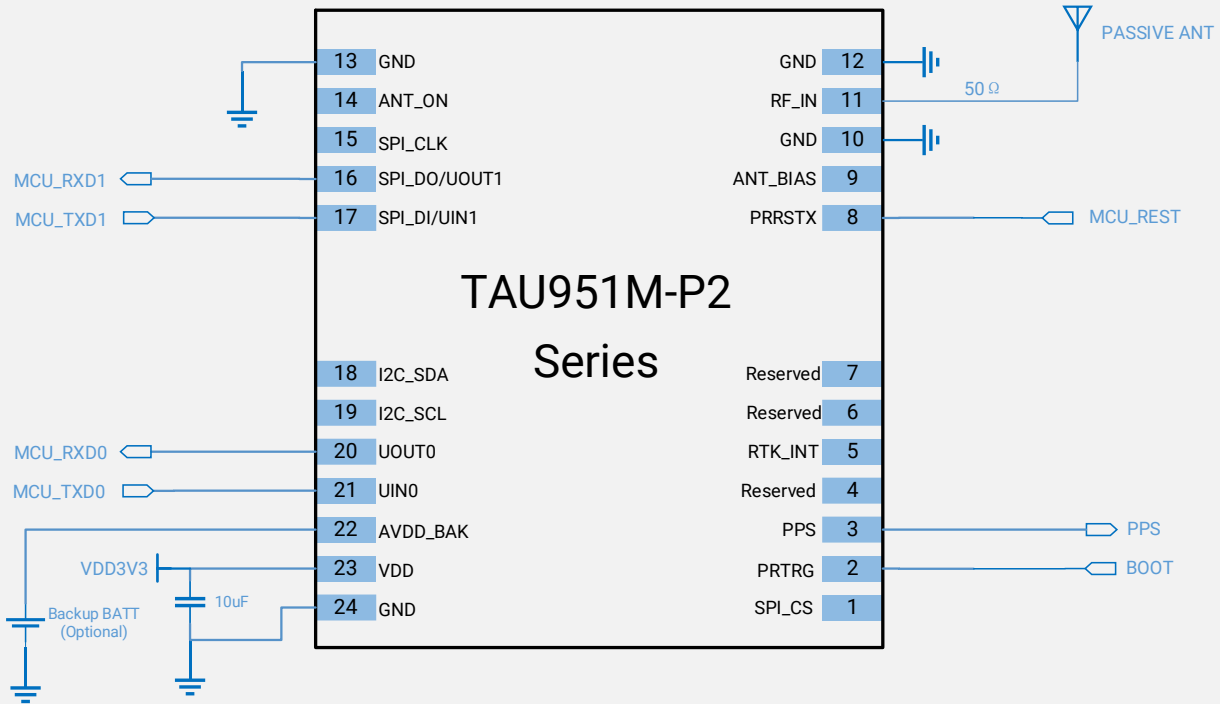

Figure 10 Reference design of passive ant.

## 6.2 PCB Footprint Reference

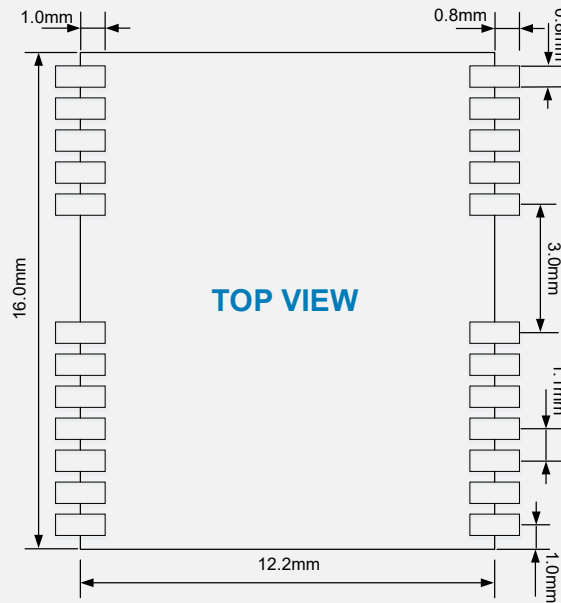

Figure 11 PCB Footprint Reference

### 6.3 Layout Notes

- 1) A decoupling capacitor should be placed close to VDD pin of the module, and the width of power routing should be more than 0.5 mm.
- 2) The width of RF routing between RF port to antenna interface should be wider than 0.2 mm. The characteristic impedance of RF routing between RF port to antenna interface should be controlled to 50Ω.
- 3) It is recommended that the routing from RF port to antenna interface refers to the second layer, and no routing are recommended on the layer.
- 4) Do not place the module close to any EMI source, like antenna, RF routing, DC/DC or power conductor, clock signal or other high-frequency switching signal, etc.

## 7 DEFAULT MESSAGE

**Table 9 Default message**

Interface	Settings
UART output	Data format: 8 data bits, no parity bit, 1 stop bit Default baud: 115200 bps Configured to transmit both NMEA and HD Binary protocols, but only the following NMEA (and no HD Binary sentence) messages have been activated at start-up: GGA, GSA, GSV, RMC, ZDA, TXT-ANT
UART input	Data format: 8 data bits, no parity bit, 1 stop bit Default baud: 115200 bps Default protocol: HD binary protocol, RTCM message.
PPS	1 pulse per second, synchronized at rising edge, pulse length 100 ms

\* Refer to *GNSS\_Protocol\_Specification* for information about other settings.

The default configuration and output information of UART0 and UART1 are identical, among which UART1 cannot be used for firmware upgrade. If the UART is connected well to the MCU when VDD is off, a high UART level may cause residual power on VDD, leading to power on failure. Therefore, when VDD is off, it is advisable to disconnect the UART or set MCU\_UART to the input or high resistance state.

## 8 PACKAGING INFORMATION

### 8.1 Packing

The module is a Moisture Sensitive Device (MSD) and Electrostatic Sensitive Device (ESD). During packing and shipping, it is strictly required to take appropriate MSD handling instructions and precautions. The table below shows the general packing hierarchy for the standard shipment.

**Table 10 Packing hierarchy**

Module	Reel	Sealed bag	Packing box	Shipping carton
				

#### 8.1.1 Tape and Reel

TAU951M-P2 series is delivered as hermetically sealed, reeled tapes in order to enable efficient production, production lot set-up and tear-down. The figure below shows the tape dimensions.

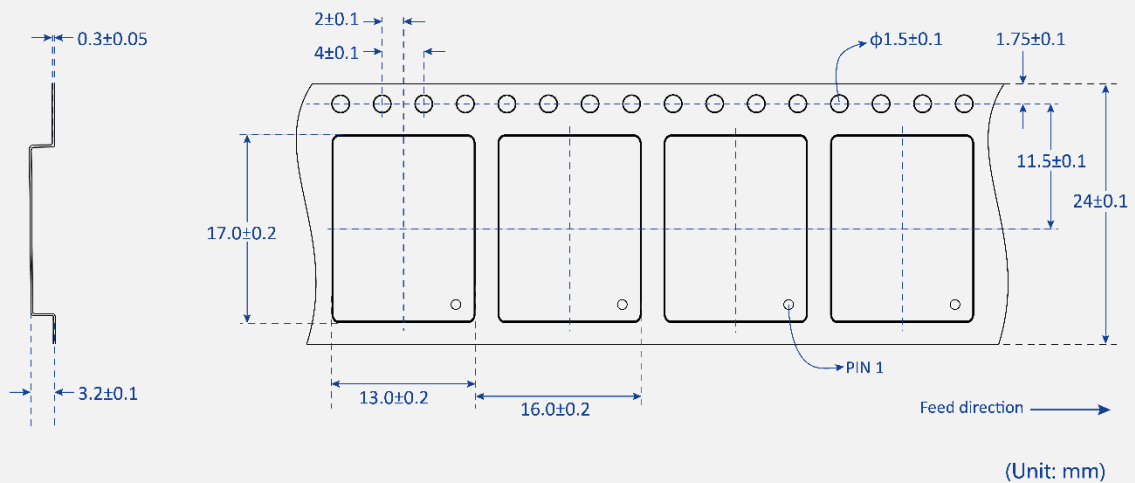

**Figure 12 Tape dimensions**

TAU951M-P2 series is deliverable in quantities of 1000 pcs on a reel. The figure below shows the dimensions of the reel.

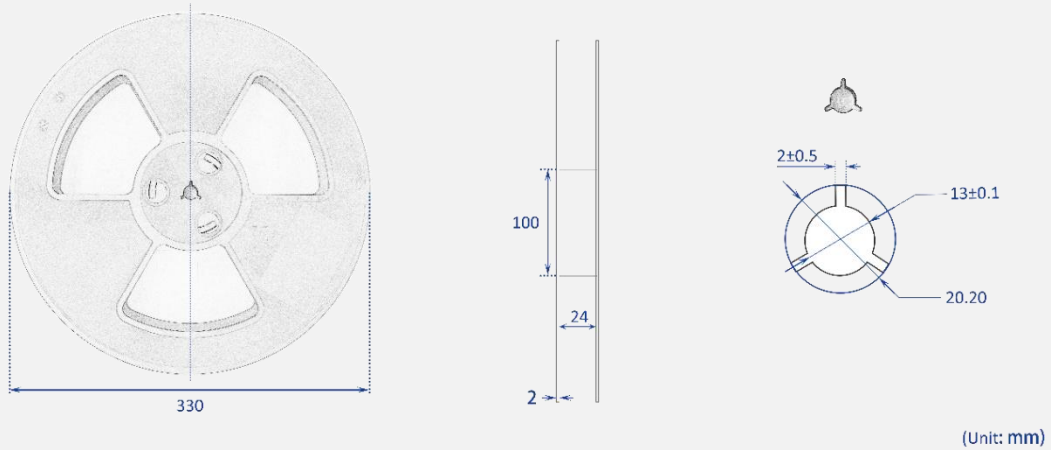

Figure 13 Reel dimensions

### 8.1.2 Shipment Packaging

The reels are packed in the sealed bags in a box and shipped by shipping cartons. Up to five boxes (1000 pcs in total) can be packed in one shipping carton.

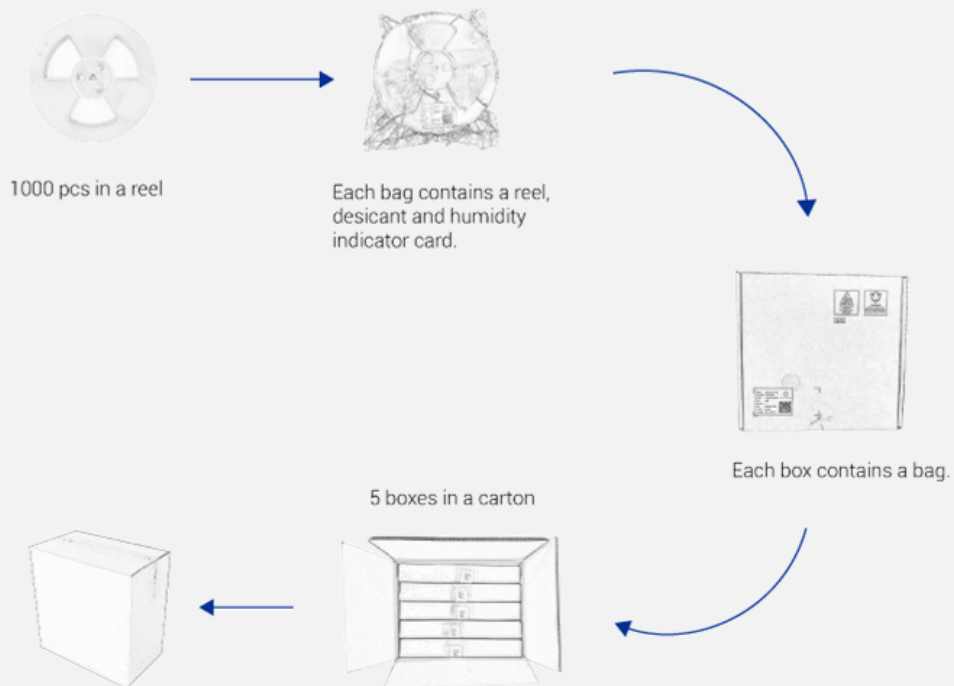

Figure 14 Packaging

### 8.2 Storage

In order to prevent moisture intake and protect against electrostatic discharge, TAU951M-P2 series is packaged together with a humidity indicator card and desiccant to absorb humidity.

## 8.3 ESD Handling

### 8.3.1 ESD Handling Precautions

TAU951M-P2 series which contains highly sensitive electronic circuitry is an Electrostatic Sensitive Device (ESD). Observe precautions for handling! Failure to observe these precautions may result in severe damage to the GNSS module!

- Unless there is a galvanic coupling between the local GND (i.e. the workbench) and the PCB GND, then the first point of contact when handling the PCB must always be between the local GND and PCB GND.
- Before mounting an antenna patch, connect ground of the device.
- When handling the RF pin, do not come into contact with any charged capacitors and be careful when contacting materials that can develop charges (e.g. patch antenna ~10 pF, coax cable ~50 - 80 pF/m, soldering iron ...)
- To prevent electrostatic discharge through the RF input, do not touch any exposed antenna area. If there is any risk that such exposed antenna area is touched in non ESD protected work area, implement proper ESD protection measures in the design.
- When soldering RF connectors and patch antennas to the module's RF pin, make sure to use an ESD safe soldering iron (tip).



### 8.3.2 ESD Protection Measures

The GNSS positioning module is sensitive to static electricity. Whenever handling the module, particular care must be exercised to reduce the risk of electrostatic charges. In addition to standard ESD safety practices, the following measures should be taken into account.

- Adds ESD Diodes to the RF input part to prevent electrostatics discharge.
- Do not touch any exposed antenna area.
- Adds ESD Diodes to the UART interface.

### 8.3.3 Moisture Sensitivity Level

The Moisture Sensitivity Level (MSL) of the GNSS module is MSL3.



## 9 LABELING AND ORDERING INFORMATION

Labeling and ordering information help customers get more about Allystar products.

### 9.1 Labeling

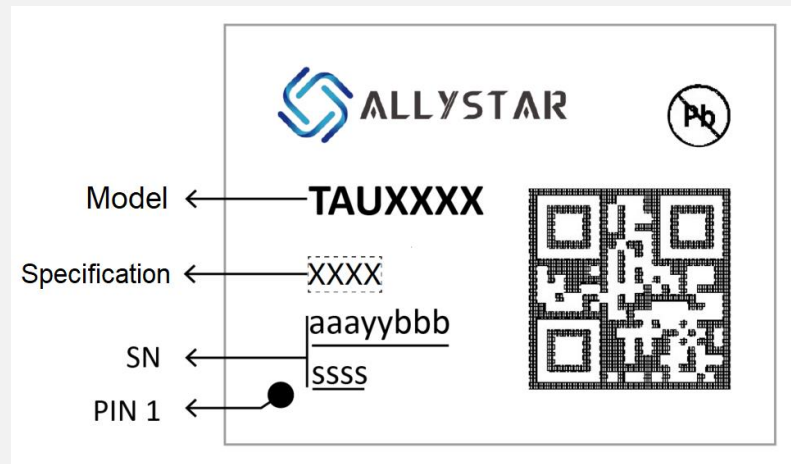

Symbol	Explanation	Sample
TAUXXXX	Product model for market promotion.	TAU951M
XXXX	Specification. The first letter represents product function; the second represents bands supported, and the following two letters show that it is standard configuration.	P200
aaayybbbssss	Serial number	392190010001

### 9.2 Ordering info

Table 11 Ordering codes

Ordering No.	Product
TAU951M-P200	Concurrent GNSS LCC Module, dual-band, RTK, TCXO, 16×12.2 mm, 1000 pieces/reel

## 10 REVISION HISTORY

Revision	Date	Revised by	Status/Comments
V1.0	2024-01	Berry	First release.



[www.allystar.com](http://www.allystar.com)



[info.gnss@allystar.com](mailto:info.gnss@allystar.com)



## Headquarters

Allystar Technology (Shenzhen) Co., Ltd.

Address: 201-2, 2F, Tower F, Xinghe World, No.1, Yabao Road, LongGang District,  
Shenzhen City, Guangdong Province, China.

